

Data and performance

Technical characteristics		
Voltage	V	104~166.4
Current	A	577(MAX)
Charge power	kW	max. 240
Dimensions (L*W*H)	mm	6058*2438*2591
Weight	T	21
Ambient temp.	°C	-20~50 (other temperatures optional)
Storage temp.	°C	0~45(long term storage)(SOC=50%)
Enclosure		IP54 (optional IP65)
Short circuit current	A	2500
Lifetime	cycles/years	+20.000 / +25
Communications		Modbus/TCP/CANbus/Ethernet
Certifications		IEC 62932-1&IEC 62932-2
BMS		Embedded
Auxiliary supply		380V/AC, 50Hz, Three-phase Stop:0.2kW; Operation:3.2kW-8.6kW

Discharge performance			
Duration (Hour)	Power (kW)	Energy (kWh)	Efficiency (%)
4	60	240	80
6	40	240	80
8	30	240	80
10	24	240	80
12	20	240	80

10kW/40kWh charge and discharge curve

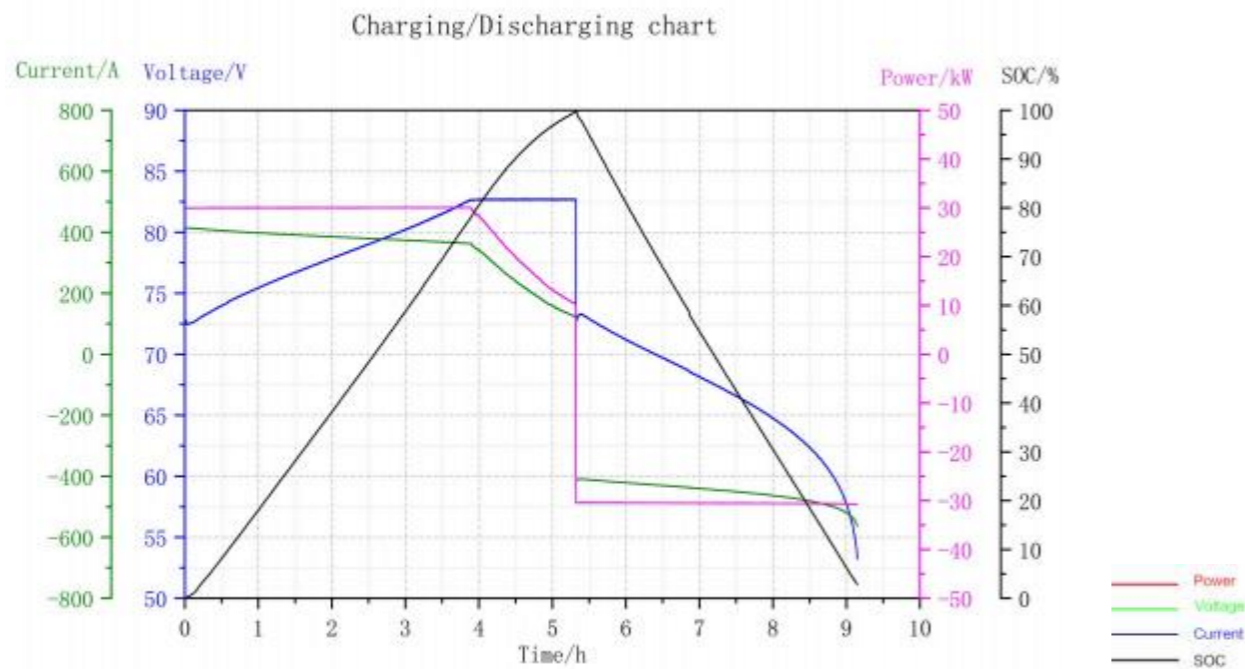

SPower 240o

A safe and sustainable battery for valuable long duration & heavy cycling application

Brochure



High modularity

Scalable | Reliable | Future-Proof

- ✓ Modular Design – Easily expandable to meet growing energy demands
- ✓ High Energy Density – 2X more capacity than conventional batteries
- ✓ Auto-Balancing & Seamless Bypass – Ensures stable performance & uptime
- ✓ Air-Cooled & Waterproof (IP54-optional up to IP65) – No liquid cooling needed, withstands submersion up to 1.4m
- ✓ Globally Certified & Patented – Compliant with international safety standards

Why Choose SPower 240o?

- ✓ Flexible Expansion – Start small, scale as needed
- ✓ Lower Footprint – Compact design saves space
- ✓ Ultra-Reliable – Built for 24/7 operation
- ✓ Smart Management – Auto-balancing & bypass for efficiency

Ideal For:

- ◇ Solar & Wind Energy Storage
- ◇ Commercial & Industrial Peak Shaving
- ◇ Microgrids & Off-Grid Power
- ◇ EV Charging & Backup Systems



Long duration & heavy cycling

Unlimited cycles, no capacity loss over life

- > Partically unlimited cycles at 100% DOD
- > No capacity fade and infinite cycle life based on vanadium redox chemistry
- > 25+ years with no degradation
- > Capable of long discharge duration up to 24 hours or even longer



+20.000 cycles/
+25 years

0% thermal runaway

Non-flammable electrolyte

0% capacity fade

IEC certified

Safety through innovation

Innovative Safety |Hybrid Thermal Management (Passive + AC Cooling) | Reliable Energy Storage

Unmatched Safety Features

- ✓ Aqueous electrolyte - non-flammable, non-toxic, no thermal runaway risk
- ✓ No Thermal Runaway – Stable chemistry prevents dangerous overheating
- ✓ Short-Circuit Resilient – No lasting damage even in fault conditions
- ✓ Built-In Heat Absorption – Electrolytes act as a natural heat sink, minimizing temperature rise

Hybrid Thermal Management (Passive + AC Cooling)

- ✓ Self-Regulating Temperature – Cools during charge, minimal heat during discharge
- ✓ High Thermal Mass – Electrolytes buffer temperature fluctuations
- ✓ Ideal for Hot Climates – Perfect for solar integration in high-temperature regions



Sustainable

- > SPower 240o 100% recyclable
- > Electrolytes 100% reused or recycled into value chemicals
- > Permanently retaining vanadium value, facilitating leasing
- > Electrolytes made most from industrial wastes, such as soot ashes, slags, etc.



Scalable

SPower 240o is a high-volume commodity product tailored to ensure modularity, flexibility and durability to support a variety of use cases from 240 kWh to several thousand kWh.

The energy storage solution enhances the stability and controllability of power generation sources. By coupling the renewable energy power plants, like windfarms and solar photovoltaic installations, with RKP's vanadium flow battery systems, the generated energy can be optimally utilized.

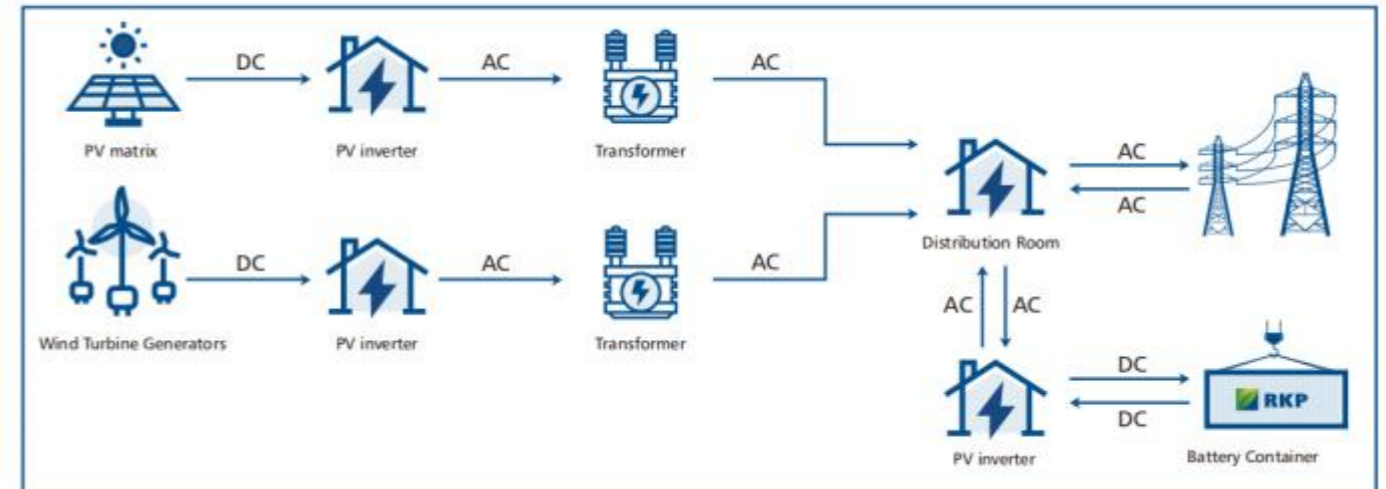

Low levelized costs over life

- > Practically unlimited cycles at 100% DOD
- > No capacity fade and infinite cycle life based on vanadium redox chemistry
- > Minimum maintenance over life
- > End-of-Life recycling with positive net value
- > Facilitating leasing to reduce capital cost
- > Competitive CapEx that drops quickly along production scaling up



25+ years

Full depth of discharge

Highly recyclable

Flexible dispatch

Lower total cost of ownership

Proven broad application

Storage applications range from grid stability and optimization to commercial, industrial storage with substantial cost savings and operational benefits.



Bulk storage

- > Peak shaving
- > Power resiliency
- > Control regulations and ancillary services
- > T&D deferral



Microgrids

- > On-grid or off-grid
- > Reliability and sustainability
- > Maximize PV and wind utilization
- > Diesel replacement and fuel savings



Commercial and industrial

- > Demand charge reduction
- > Time of use savings
- > Flexible capacity/ramping
- > Load shifting and electricity warehousing



Renewable integration

- > Time shift
- > Smoothing
- > Firming



Back-up power

- > Critical facilities such as hospitals and data centers must have resilient and redundant power feeds
- > A reliable alternative for diesel generators

Contact us

HEADQUARTERS

RKP International Limited
HONGKONG
SAR
<https://rkpstorage.com>

BANCHOFFICES-UNITED ARAB EMIRATES

RKP ENERGYSTORAGE MIDDLE EAST-FZCO
DUBAI
UNITED ARAB
EMIRATES.<https://rkpstorage.com>

BANCHOFFICES

AUSFLOW ENERGY PTY LTD
BRISBANE
AUSTRALIA
<https://ausflowenergy.com>

BANCHOFFICES-GERMANY

RKP GERMANY UG
(haftungsbeschränkt)BERLIN
GERMANY
<https://rkpstorage.com/de>

Note: We reserve the right to make technical changes or modify the contents of this document without prior notice. With regard to purchase orders, the agreed particulars shall prevail. RKP does not accept any responsibility whatsoever for potential errors or possible lack of information in this document.

We reserve all rights in this document and in the subject matter and illustrations contained therein. Any reproduction, disclosure to third parties or utilization of its contents – in whole or in parts – is forbidden without prior written consent of RKP.

Rongke Power (RKP) © 2025. All Rights Reserved

Document Version	Release Date	Revision History
V1.0	2025-04-16	Official Launch (V1.0)